

1st European SystemC™ Users Group Meeting, Munich, January 31st, 2000

Minutes
(February 5, 2000, 15:09)

Welcome (11:00)

Speaker:

Wolfgang Rosenstiel

Topic:

What is SystemC™?

Benefits of a C++ based SoC design flow (executable specification, high speed simulation, no translation but refinement into HDL, testbench reuse). Short introduction to SystemC™ (SystemC™ design methodology, key features of the SystemC™ modeling platform, Open Community Licensing model).

Goals of the European SystemC™ Users Group

News from the SystemC™ Steering Group, goals of the SystemC™ Users Group, time schedule for SystemC™ Users Group events, technical news (SystemC™ Release 0.91 and SystemC™ Release 1.0).

Invited Speakers (11:30)

Speaker:

Daniel Schmidberger (Sun Mirosystems)

Topic:

Web Centric Engineering

The business model for Open SystemC™ is similar to Sun's Community Source Licensing, which has been proven to combine advantages of open source and proprietary licensing approaches. For open evolution in internet time, high speed networks are needed to increase engineering productivity and to bundle computational resources.

Speaker:

Albrecht Mayer (Infineon Technologies)

Topic:

SystemC™ – Benefits for SoC Design

C++ is a powerful, versatile and cost effective platform for system simulation. Infineon has created and used a proprietary C++ class library for modeling. Reasons for Infineon to support SystemC™ are, that SystemC™ provides the advantages of a standard (maintenance, exchange with customers) and opens the path to implement (parts of) the model directly with synthesis. Infineon did successfully use SystemC™ in two design projects, a Capture-Compare Unit Peripheral and a GSM Baseband Chipset.

Lunch (12:30)

Users Group Activities (13:30)

Formation of Working Groups

Identification of discussion topics:

Topic-1: Application oriented SystemC™ requirements

Topic-2: SystemC™ and existing description languages

Topic-3: Modeling standard SoC components in SystemC™

Topic-4: SystemC™ for system level validation

Working Group Discussions

Identification of working group moderators, group internal discussions.

Coffee Break

Working Group Reports

Presentation of discussion summaries by the working group moderators.

Topic-1: Application oriented SystemC™ requirements

Moderator: Andreas Merz, Philips Semiconductors

Discussion Points:

- Focus application areas, based on the background of the participants were: embedded systems, wireless communications, network-processors, education.
- TCO (total cost of ownership) transparency
 - Licensing, patents, libraries
 - Which additional tools for efficient work are needed or recommended?
 - Important tools currently not available? (e.g: SystemC™-to-VHDL compiler)
 - Decision-takers and project leaders in a company need information about the amount of work and money, needed to introduce SystemC™ in one of the above application areas. This information has to be available on the web.
- Documentation
 - Within the code?
 - Easy extraction or communication of know how in specific application areas.
 - automatic doc-generation for SystemC™ lib-functions and user functions? (e.g. doc++) for better consistency of code and documentation.
 - Coding-style recommendations
- Libraries
 - Known location (<http://www.systemc.org> ?)
 - Searchable, well-documented, also sorted wrt. application area.
 - Sufficiently large base of free modules (universities..., education)

- CVS-repositories for version management?
- Portability
 - Cross-platform interfacing with tools, commonly used in certain application areas e.g. MatLab, COSSAP, SPW, SPICE.
 - Master- and Slave- capability for use within heterogeneous simulation setups!
 - Cross-compilers to and from SystemC™ to ensure future value of IP written in SystemC™.
- Parallel Processing Support
 - SystemC™ simulations must run on network computers and parallel processor machines.
 - Supportive SystemC™ library functions or compiler options for distributed simulation systems.
 - In certain application areas (e.g. Wireless) systems tend to grow very fast. To prevent early bottlenecks in simulation speed, future-oriented processing concepts should be taken into account from the very beginning.

Topic-2: SystemC™ and existing description languages

Moderator: Martin Erdmann, Infineon Technologies

Discussion Points:

- Flow:

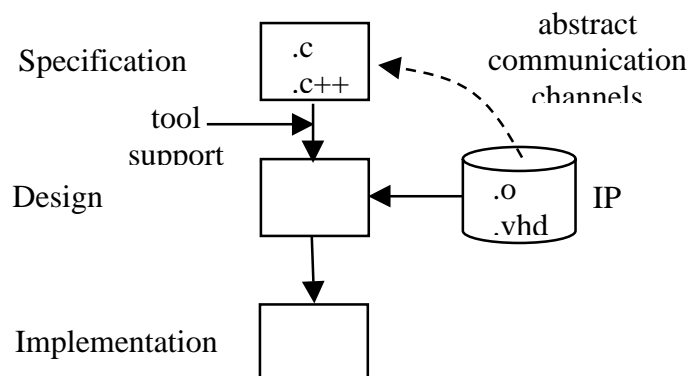

- General aspects:
 - Simulation speed restrictions
 - No principal differences between SystemC™ and HDLs
- Cosimulation vs. Translation
 - Pro Cosimulation: First step, less risky
 - Pro Translation: One environment, faster simulation

Topic-3: Modeling standard SoC components in SystemC™

Moderator: Frank Franssen, CoWare

Discussion Points:

- Mixed attendees (SoC, academic, semiconductor, ASIP, ROTS, Mixed Signal / Analog, CAD engineering, EDA)
- Standardization effort has to satisfy needs from the various parties:
 - Support partitioning mechanism (tools)

- Support mapping info (expression of relationships) from functional specification to implementation (HW and SW architectures)
- Support test and design of testbenches (enable timing information exchange)
- Support different abstraction levels (top-down refinement with IP)
- Support analog interfacing (a.o. Matlab link)
- Expected benefits of standardization SoC components:
 - Enable full Co-SW-HW-development
 - Increases tool development
 - Enables customer verification
 - Makes IP available to speedup design, and SystemC™ will allow C people to design SoC (large designers base).
 - Facilitate plug&play design and reducing customizing effort
 - Facilitate generation of IP components (advantage from vendors point of view)

Topic-4: **SystemC™ for system level validation**

Moderator: Gerard Wolters, National Semiconductor

Discussion Points:

- Modeling:
 - HW seems to be covered
 - SW seems to need improvement (RTOS support, interfaces to other SW / HW)
 - Refinement from transaction-accurate to cycle-accurate starting from the same description
 - Need of a model library of building blocks
- Simulation:
 - Simulation speed is very important
 - Higher levels of abstraction
 - Functional analysis,
 - Architectural analysis – either by language or tools
 - Ability to use SW constructs for communication modeling
 - Has to support all levels from behavior to cycle-accurate
 - Integration to existing simulation environments (VHDL environments, SW debugging environments)
- Rapid Prototyping:
 - Support for generation of test environments
 - How to ensure correct functionality of SystemC™
 - Has to fit into existing environments
- Validation / Verification:
 - Validation is a very time consuming task
 - Is there any way for formal specification
 - Definition of abstract concepts for verification
 - Possibility to pass constraints into the language
 - Functional Constraints (e.g. loop invariants, “variable a is always >0”)

- Timing constraints (for real time systems, e.g. “block b has to be handled within n seconds”)

Closing Remarks (16:30)

Speaker:

Wolfgang Rosenstiel

End of Meeting (16:45)

Joachim Gerlach,
University of Tübingen,
Email: gerlach@informatik.uni-tuebingen.de
Phone: ++49-7071-2977347
Fax: ++49-7071-295062